

D4 PMO Series

DOUBLE SEAT MIX PROOF VALVES

FORM NO.: 95-03105 REVISION: 6/2020

READ AND UNDERSTAND THIS MANUAL PRIOR TO OPERATING OR SERVICING THIS PRODUCT.



Contents	Page
1. General Terms	4
2. Safety	4
2.1. Symbols	4
2.1. Safety Instructions	4
3. Intended Use	5
4. Mode of Operation	6
4.1. General terms	6
4.2. Valve in "closed" position	6
4.3. Valve in "open" position.....	7
5. Control Units / Valve Position Indication	7
5.1. Control unit and adapter	7
6. Cleaning	8
6.1. Flow area	8
6.2. Seal surfaces and seat area	8
6.3. Cleaning recommendation	8
6.4. Cleaning of upper area (fig. 5)	9
6.5. Cleaning of lower area (fig. 6)	9
7. Installation and Commissioning	10
7.1. Welding Instructions.....	10
8. Dimensions / Weights	11
9. Technical Data	12
9.1. General data	12
9.2. Compressed air quality	12
9.3. Cvs values in gpm.....	13
9.4. Air consumption / Switching times	13
9.5. Valve stroke / Opening cross section	14
10. Maintenance	15
11. Service Instructions	16
11.1. Removal from the line system.....	16
11.2. Removal of product-wetted parts	17
11.3. Installation of product-wetted seals and assembly of the valve	18
11.4. Installation of the valve insert	19
12. Maintenance of Actuator	20
12.1. Removing the actuator screws	20
12.2. Installing the seals and assembling the actuator	20
13. Assembly Instructions and Tools for Seals	21
13.1. Lower shaft seal.....	21
13.2. Seat seals.....	22
14. Trouble Shooting	23
15. Spare Parts Lists	23
15.1. D4 PMO Drawing and Parts List.....	24

1. General Terms

This instruction manual should be read carefully by the competent operating and maintenance personnel.

We point out that we will not accept any liability for damage or malfunctions resulting from the non-compliance with this instruction manual.

Descriptions and data given herein are subject to technical changes.

2. Safety

2.1. Symbols



Caution!

The technical safety symbol draws your attention to important directions for operating safety. You will find it wherever the activities described are bearing health hazards and risks for persons and / or material assets.



Important Note!

Critical technical information

2.1. Safety Instructions



**Opening of the actuators and upper shafts is strictly forbidden.
Danger to health and life!**

Actuators and upper shafts which are no longer used and/or are defective must be disposed in a professional manner.

Defective actuators and upper shafts must be returned to your SPX FLOW company for professional disposal, free of charge to you.

Please address to your local SPX FLOW company.



- Never touch the valve or pipelines during hot liquid or sterilization processes!



- Disconnect electric and pneumatic connections before performing any maintenance work.



- Before performing any maintenance work, depressurize the line and cleaning system and fully discharge the lines, if possible.

2. Safety



- Observe all service instructions to ensure safe maintenance of the valve.



- Connections which are not used must be sealed by a plug!



- The safe discharge of the cleaning liquids must be ensured.



- The valves must be assembled, disassembled, and reassembled only by persons who have been trained in the valves or by SPX FLOW service team members. If necessary, contact your local SPX FLOW representative.

3. Intended Use

The D4 PMO valves allow for safe separation of milk and milk products from cleaning and sanitizing solutions as well as single seat clean separation while milk is in the opposite housing. They are designed for installation in a milk processing system operating in compliance with the Pasteurized Milk Ordinance Section 7, Item 15p.(B) and meet the 3-A standard 85-03 for double seat mix proof valves.



Warning! PMO Double seat mix proof valves cannot be used to separate raw milk and milk products from pasteurized milk, milk products, and other comestibles.



Caution! The D4 PMO valve must not be used in explosive atmospheres.



Caution! Arbitrary, structural changes at the valves may affect safety as well as the intended functionality of the valves and are not permitted.

Authorizations and External Approvals

To search for 3-A certificates, go to www.3-a.org/3-A-Symbol/Search-Database-of-Current-Certificates. From here, you can search by Company, Certificate Number, or Standard.

Company: SPX Flow US, LLC; Certificate No.: Certificate 1369; Standard: 85-03.

4. Mode of Operation

fig. 1: D4 PMO valve

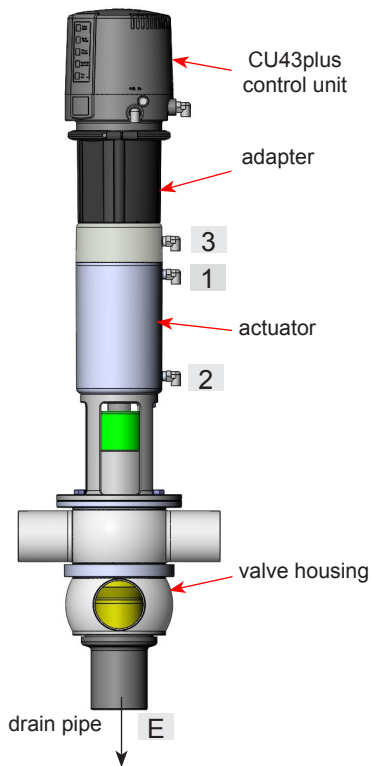

4.1. General terms

Due to its construction and mode of operation as well as to the use of high quality stainless steel and adequate seal materials, the D4 PMO double seat mix proof valves are suited for applications in the food and beverage industries as well as in pharmaceutical and chemical applications.

- The D4 PMO valve separates two line passages by two independently operating valve shafts with an intervening leakage chamber.
- The valve opens from the top to the bottom in a low-leakage design.
- Leakages are discharged via the drain pipe (E) in a depressurized state.
- The pneumatic actuator opens the valve via the air connection (1). The actuator's spring force resets the valve into the "closed" safe position.
- The standard D4 PMO valve is equipped with a seat lift actuator and CU43plus control unit.
- D4 PMO valve:
Cleaning of the seat is controlled via the air connections:
2 = to lift upper shaft
3 = to lift lower shaft

fig. 2

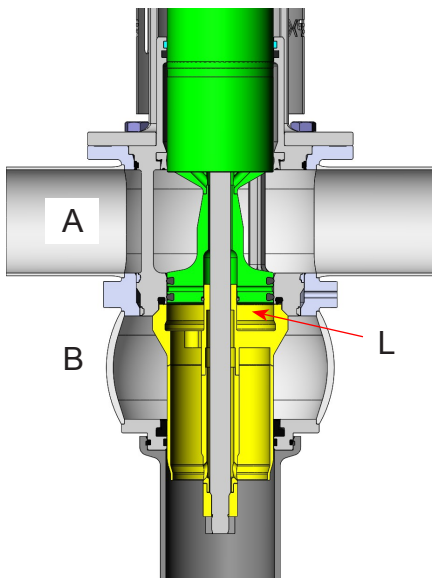

4.2. Valve in "closed" position

The lower and upper valve shafts are in closed position and safely separate the different liquids A and B. The leakage chamber L, which is situated between the two valve shafts, provides for a free and depressurized discharge to the bottom.

4. Mode of Operation

fig. 3

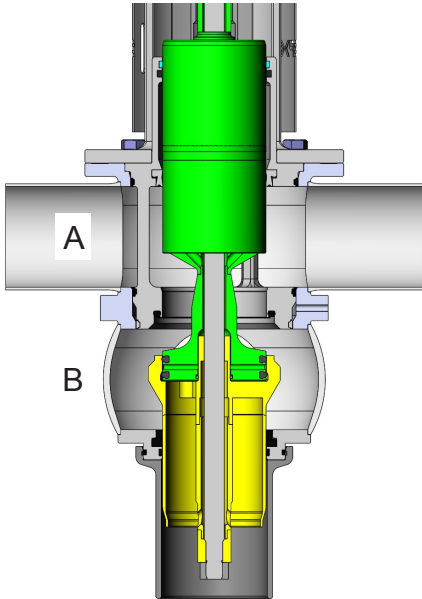

4.3. Valve in "open" position

The upper valve shaft is sealed inside the lower shaft by radial seals. First, the upper shaft is sealed inside the lower shaft. Then the two valve shafts move downwards into the open position. The connection between the two pipelines A and B is established.

5. Control Units / Valve Position Indication

fig. 4: CU43plus control unit



5.1. Control unit and adapter

An adapter, part number H336441, is required to assemble the control unit on the D4 PMO valve.

Control unit part numbers

Size	Part number
1/4" OD, set for D4SL/D4PMO	H342414
1/4" OD M12 - 4 pin, , set for D4SL/D4PMO	H342412

See https://www.spxflow.com/assets/pdf/APV_valves_control_units_CU4plus_AS-interface_GB.pdf for the current CU4plus control unit manual.

6. Cleaning

In the cleaning process of the valves, distinction is made between the following areas:

6.1. Flow areas

The CIP-fluid cleans the upper and lower passages of the valve during CIP.

6.2. Seal surfaces and seat area

(See sections 6.4 and 6.5) The seal surfaces of the upper area (upper shaft and seat seal) and the lower area (lower shaft and seat seal) are flushed and cleaned when the individual valve shafts are lifted during cleaning. The seat area and leakage chamber are also cleaned during this process.

6.3. Cleaning recommendation

Cleaning steps	Seat lifting cycle
pre-flushing	–
caustic flushing 176°F (80°C)	3 x 5 sec.
intermediate flushing	2 x 5 sec.
acid flushing	3 x 5 sec.
subsequent flushing	2 x 5 sec.

- The lifting cycles refer to a cleaning pressure of
 $p = 29 - 72 \text{ psi (2-5 bar)}$.
- Depending on the product being processed, adjust the pressure, cleaning temperatures, cleaning steps, time, and number of cycles as required to achieve acceptable cleaning.



Caution!

The cleaning liquid applied must be compatible with the respective seal material.

6. Cleaning

fig. 5

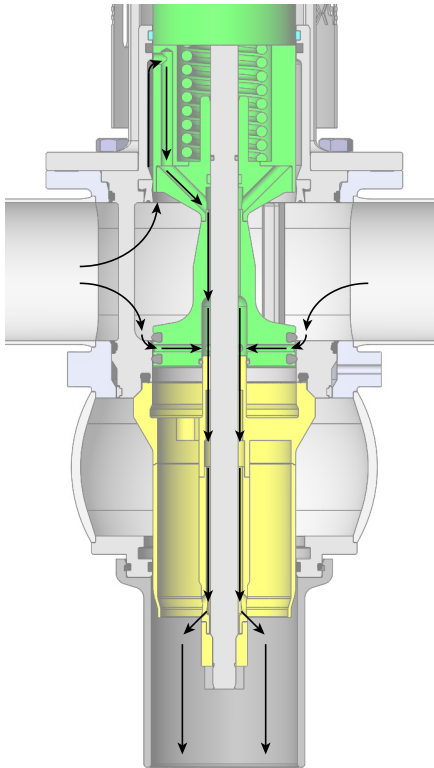

6.4. Cleaning of upper area (fig. 5)

The upper valve shaft is lifted via connection (2), as shown in fig. 1 on page 6.

Through the lifting of the upper valve shaft, the cleaning fluid flushes over the upper seat seal and the upper valve seat into the leakage chamber and cleans this area. The cleaning fluid is drained off to the bottom in a depressurized state.

Simultaneously, the upper shaft seal and the outer surface of the upper valve shaft are cleaned. The cleaning fluid is guided into the leakage chamber and drained off to the bottom.

The lifting stroke is limited by a metallic stop.

fig. 6

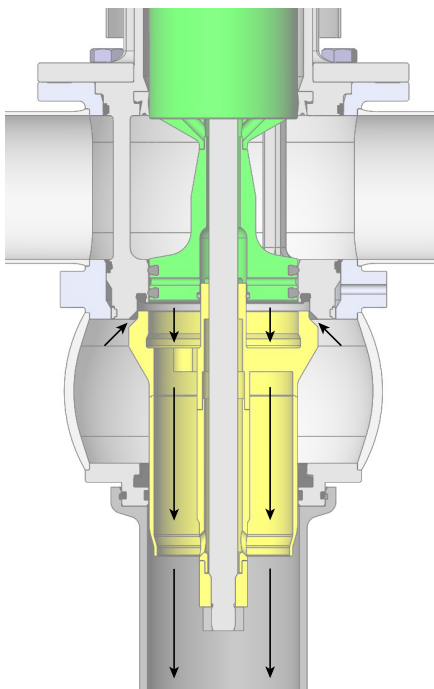

6.5. Cleaning of lower area (fig. 6)

The lower valve shaft is lifted via connection (3), as shown in fig. 1 on page 6.

Through the lifting of the lower valve shaft, the cleaning fluid flushes over the lower seat seal into the leakage chamber and cleans this area. The cleaning fluid is drained off to the bottom in a depressurized state.

The lifting stroke is limited by a stop in the actuator.

7. Installation and Commissioning

- The valve must be installed in a vertical position to ensure that fluids can drain off freely from the valve housing and the leakage chamber.



Caution! Leakages and fluid losses from seat lifting must be safely collected and drained!

- The valve housing can be welded directly into the pipeline (completely removable valve insert).



Note! Observe welding instructions.

- Observe the minimum clearance required for installation and valve insert removal. See page 11.



Caution!

Before first startup:

- Actuate the valve by applying compressed air. The opening, closing, and shaft lifting processes must run smoothly.
- Check the function of the control unit or valve position indication.
- Check for possible leakages during commissioning. Replace defective seals.

7.1. Welding Instructions

- Before welding the valve, remove the valve insert from the housing.



- **Caution!** Handle and store the valve insert carefully to avoid damaging the parts.

- Remove the lower shaft seal and guide ring from the housing.

- Welding should only be carried out by certified welders (DIN EN ISO 9606-1) (seam quality DIN EN ISO 5817).

- The welding of the valve housings must be undertaken in such a way that the valve body is not deformed.

- The preparation of the weld seam up to 0.12" (3 mm) thickness must be carried out as a square butt joint without air. Consider shrinkage!

- TIG orbital welding is recommended.



- **Caution!** After welding the valve housing or mating flanges, and after performing any work on the piping, do not operate the valves until the corresponding areas of the installation and piping have been cleaned and welding residue has been removed. If the piping is not cleaned before operation, welding residue and dirt particles can settle in the valves and cause damage to the valves and seals.

- If these welding instructions are not followed, any resulting damage will not be covered by the warranty.

- Welding directives for aseptic applications shall be drawn from the AWS/ANSI Directives and EHEDG Guidelines.

8. Dimensions / Weights

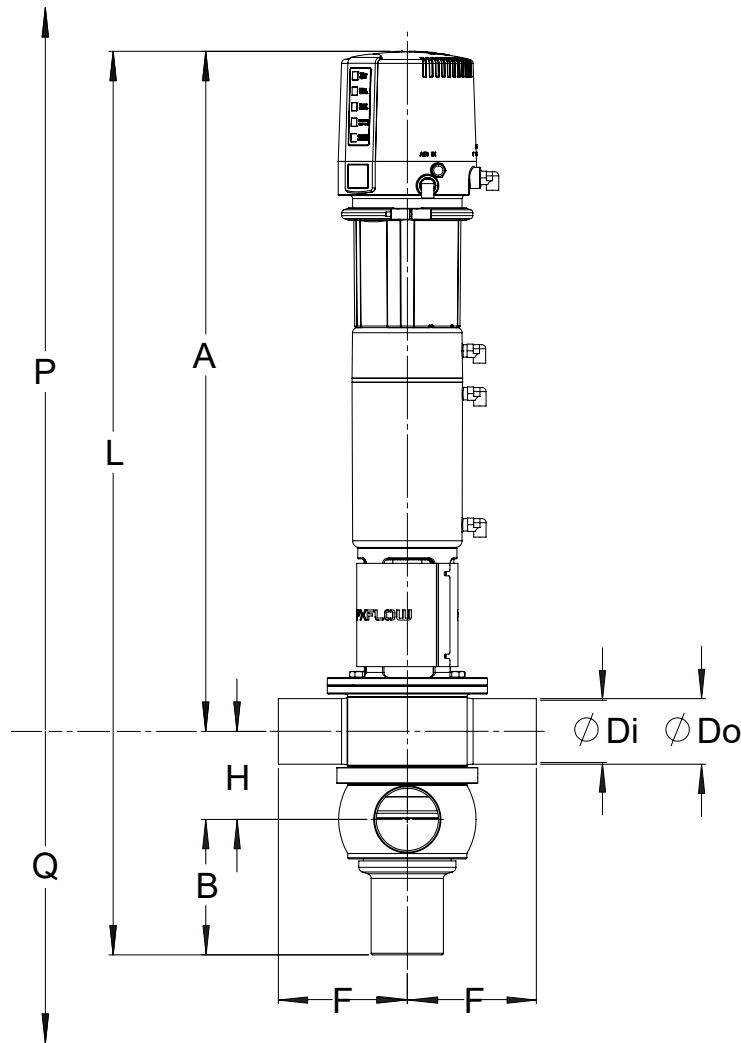

Minimum clearance required for installation and valve insert removal, IN:

Size	P (from centerline, above valve)	Q (from centerline, below valve)
1.5"	34.3	7.8
2"	34.6	8.5
2.5"	35.0	9.2
3"	35.4	9.9
4"	39.0	11.9

Dimensions in IN							
Size	A	B	Ø Do	Ø Di	F	H	L
1.5"	25.6	4.7	1.5	1.4	4.9	2.5	32.7
2"	25.8	4.9	2.0	1.9	4.9	3.0	33.6
2.5"	25.9	5.2	2.5	2.4	4.9	3.4	34.5
3"	26.2	5.4	3.0	2.4	4.9	3.9	35.4
4"	30.8	6.1	4.0	3.8	5.6	4.9	41.4

NOTE: Add the following approximate dimension to "F" for each clamp port connection: 0.5" for valve sizes 1.5" - 3.0", 0.62" for valve size 4".

9. Technical Data

9.1. General data

Product-wetted parts	AISI 316L (1.4404) (DIN EN 10088)
Other parts	AISI 304 (1.4301) (DIN EN 10088)
Seals standard options	EPDM / PTFE compound FPM/ PTFE compound
Max. line pressure	145 psi (10 bar)
Max. operating temperature	275°F (135°C) EPDM *FPM
Short-term load	284°F (140°C) EPDM *FPM *no steam
Tightening torque for stop sleeve	7 ft-lb (10 Nm)
Tightening torque for safety nuts at lower and upper valve shaft	29 ft-lb (40 Nm)
Ø Cleaning connection DN 40–100/1.5–4"	0.315 x 0.039" (8x1 mm)
Ø Air connection	1/4" OD
Max. pneumatic air pressure	116 psi (8 bar)
Min. pneumatic air pressure	72 psi (5 bar)

9.2. Compressed air quality

Quality class	acc. to DIN ISO 8573-1
Content of solid particles	quality class 3, max. size of solid particles per m ³ 10000 of 0.5 µm < d < 1.0 µm 500 of 1.0 µm < d < 5.0 µm
Content of water	quality class 3, max. dew point temperature -4°F (-20°C) For installations at lower temperatures or at higher altitudes, consider additional measures to reduce the pressure dew point accordingly.
Content of oil	quality class 1, max. 0.01 mg/m ³

The oil applied must be compatible with Polyurethane elastomer materials.

9. Technical Data

9.3. Cvs values in gpm*psi

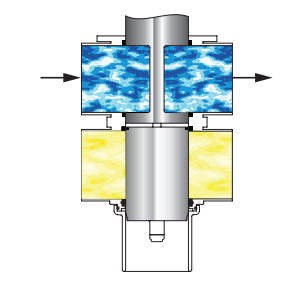
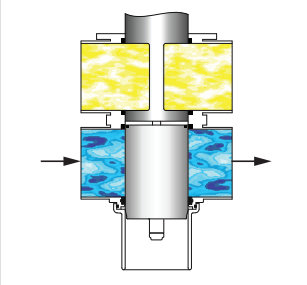
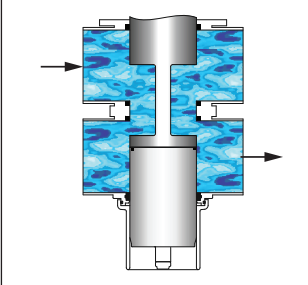
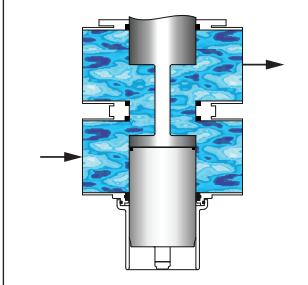
				
Size	upper line	lower line	upper - lower line	lower - upper line
1.5"	49	44	28	27
2"	96	82	53	53
2.5"	170	141	77	77
3"	212	185	96	95
4"	380	274	193	180

9.4. Air consumption / Switching times

Size	Air consumption at 72 psi (5 bar)			Switching times in seconds at 72 psi (5 bar) / CU43plus	
	Actuator	Seat lift actuator		Open	Closed
	ft ³ /stroke valve open	ft ³ /stroke upper seat lift	ft ³ /stroke lower seat lift		
1.5"	0.06	0.12	0.011	0.05	0.06
2"	0.06	0.12	0.011	0.05	0.06
2.5"	0.07	0.12	0.011	0.06	0.07
3"	0.07	0.12	0.011	0.06	0.07
4"	0.13	0.27	0.014	0.09	0.12

9. Technical Data

9.5. Valve stroke / Opening cross section

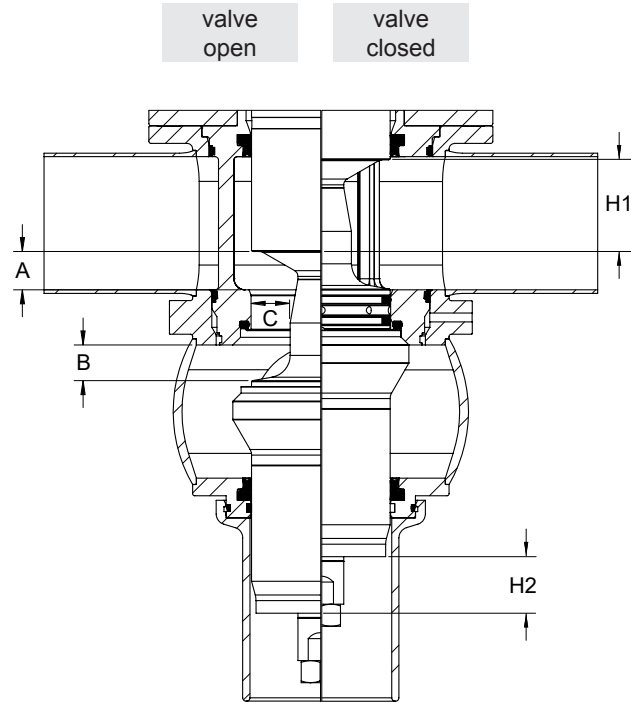

D4 PMO Valve: Dimensions in IN					
Size	A	B	C	stroke H1 upper shaft	stroke H2 lower shaft
1.5"	0.2	0.3	0.8	1.2	0.6
2"	0.5	0.4	0.8	1.4	0.8
2.5"	0.7	0.6	0.8	1.6	1.0
3"	1.0	0.9	0.8	1.9	1.2
4"	1.9	1.0	1.3	2.0	1.3

10. Maintenance



Note!

The maintenance intervals are different depending on the application and must be determined by the operator performing regular checks.

- Compressed air is not required to remove the valve.



Caution!

Do not clean the valve with products containing abrasive or polishing substances. Abrasive and polishing agents are especially harmful to the upper and lower shaft.



Required tools for standard maintenance:

- 1 x wrench SW13, SW24, SW30, SW32
- 2 x wrench SW17
- 1 x Allen key SW3, SW6
- long hook with 45° tip
- double joint forceps
- assembly stick (part no. H338450) for assembly of the lower shaft seal (see page 25)
- assembly/disassembly tool (part no. H17889) for lower shaft seal (see page 25)
- seat assembly tool (part no. 102797+) for seat seals (see page 26)
- For valve maintenance SPX FLOW offers complete seal kits (see spare parts lists).



Caution!

The use of seal materials that are compatible with the product, application, and CIP liquids must be ensured. In case of doubt, contact your local SPX FLOW representative.

- For seal replacement instructions, see section 11.2 to 11.3.
- Provide all seals with a thin layer of grease before their installation!

Recommendation:

Assembly grease for EPDM and FPM (Viton)

0.75 kg/tin - Part no. H147382

60 g/tube - Part no. H147381

- Provide all screws and threaded parts with grease before their installation.

Recommendation: Klüber paste UH1 84-201

60 g/tube - Part no. H147379

Recommendation for actuator:

Pneumatic grease: Autol TOP 2000

25 ml/tube - Part no. H164725

- For valve assembly instructions, see section 11.3.

11. Service Instructions

fig. 7

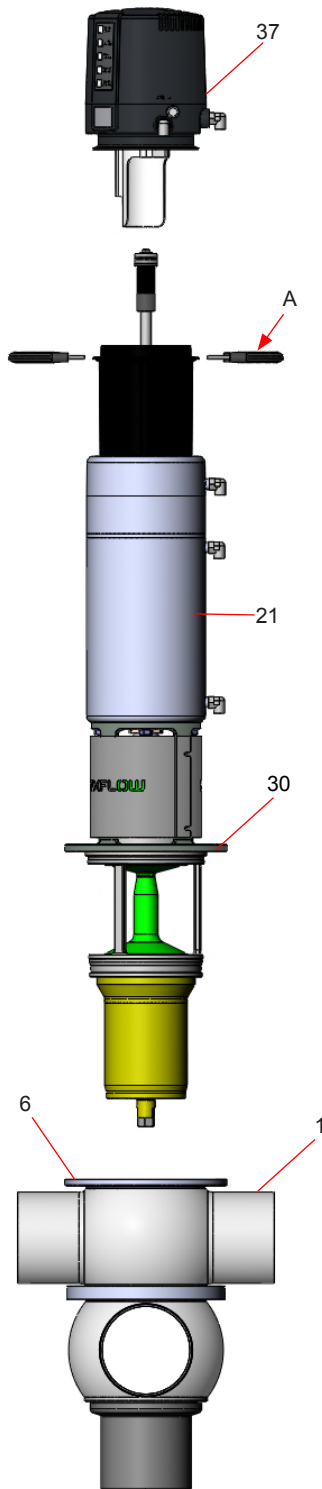

The item numbers listed refer to the spare parts drawing and parts list starting on page 28, as well as the figures referenced.

For Disassembly/Assembly tools, see page 25.

11.1. Removal from the line system

Caution!



1. Shut off the line pressure in the product and cleaning lines, and discharge the pipes, if possible.
2. Remove the compressed air lines from the valve actuator (21).
3. Release the 2 screws at the clamp rings (A) and lift the control unit (37) off the adapter.
4. Remove the flange screws (30) in the yoke (6).
5. Screw one flange screw (30) into the threaded bore of the yoke (6) to lift the complete valve insert.
Note: Do not remove the screw. It helps when re-installing the valve insert.
6. Carefully lift the valve insert vertically, out of the valve housing (1).

11. Service Instructions

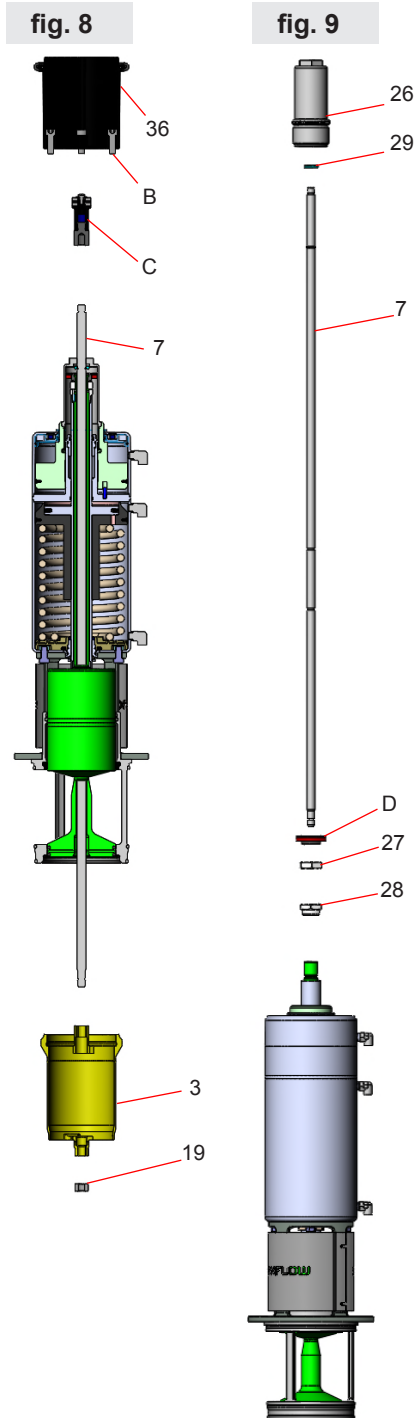

11.2. Removal of product-wetted parts

1. See fig. 8. Release the lower safety nut (19). Hold the lower shaft (3) with an SW17 wrench to keep it from turning.
2. After removing the nut (19), lift off the lower shaft (3).
3. Remove the operating cam (C) from the guide rod (7).
4. In order to take off the adapter (36), remove the 4 screws (B).
5. See fig. 9. Remove the stop screw (26).
6. Take the guide rod (7) out through the top of the actuator.
7. Remove the operating cam at the upper shaft (D).
8. Hold the lock washer (28) with a SW30 key to keep it from turning, then unscrew the safety nut (27). Remove the lock washer.

11. Service Instructions

fig. 10

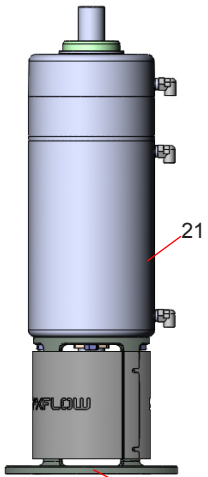
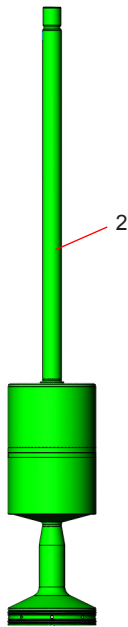
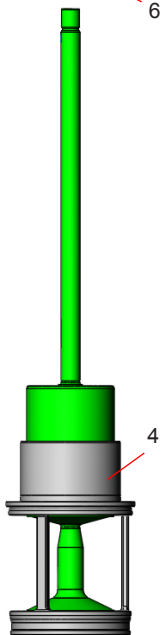
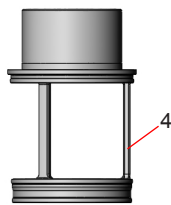

fig. 11



9. See fig. 10. Lift off the actuator (21) with the yoke (6).

10. See fig. 11. Slide the valve seat (4) over the balancer of the upper valve shaft (2).

11. Removing the seals from the valve seat (fig. 12):

Place the point of the disassembly tool (see fig. 25 on page 25) along the side of the middle seal (10) and pull it out of the groove.

Remove the three valve seat seals (12 and 5) from the outside of the valve seat (4). Remove the quad ring (15), the piston ring (17), and the seat seal (14) from the valve seat (4).

12. Removing the seals in the upper shaft (fig. 12):

Place the point of the disassembly tool along the side of the seat seals (11) and pull the seals out of the grooves of the upper shaft (2). Take the O-ring (13) out of the groove.

fig. 12

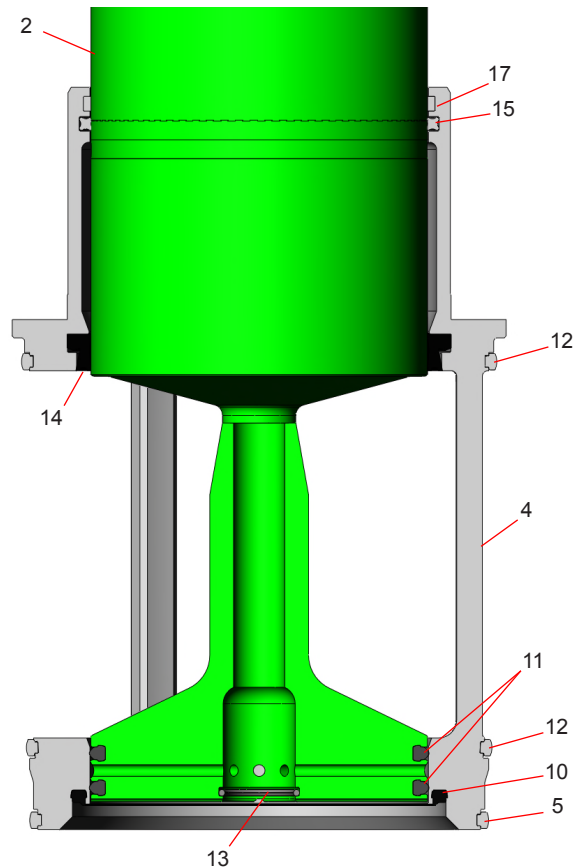

11. Service Instructions

fig. 13

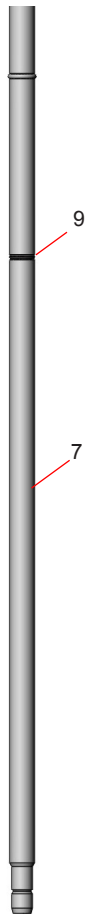

13. See fig. 13. Remove the O-ring (9) from the tie rod (7)

14. Removing the lower shaft seal from the housing (fig. 14):
Place the point of the disassembly tool along the side of the shaft seal (14) and pull it out through the top of the housing (1).

15. Place the metal point of a hook in the gap of the guide ring (17). Slightly turn the hook to lift the guide ring (17) out of the groove and housing (1).

fig. 14

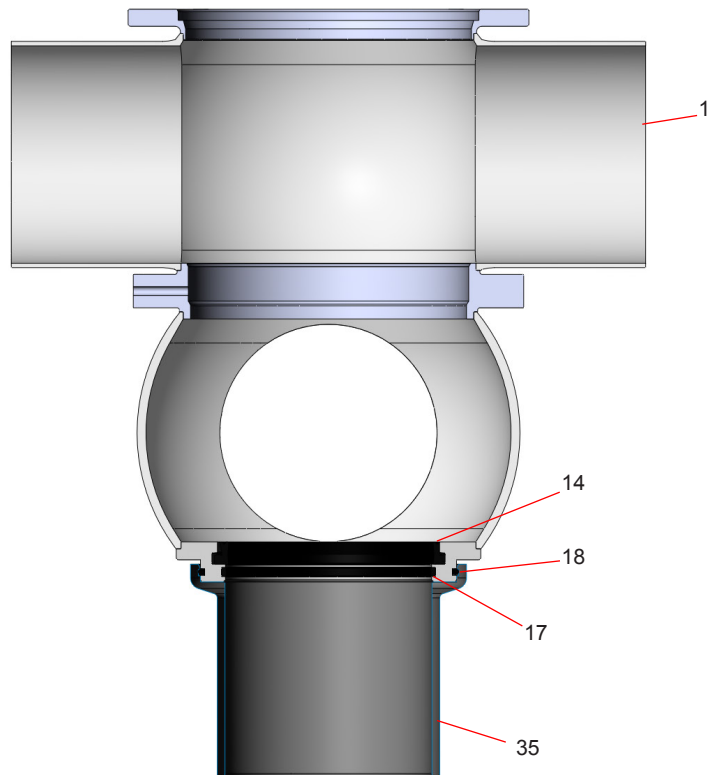

11. Service Instructions

fig. 15

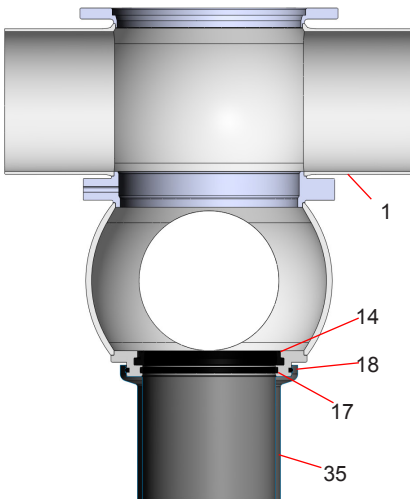

11.3. Installation of product-wetted seals and assembly of the valve



Note! Make sure that all seals and bearing surfaces in the product area are slightly greased before their installation.

1. See fig. 15. Install the piston ring (17) in the lower flange of the housing (1) using a double joint forceps. Overlap the ends of the piston ring, grasp the overlapping ends in the forceps, then insert the ring into the lower flange. Position it in place, then release the forceps, allowing the piston ring to snap into place.
2. Install the lower shaft seal (14) in the lower housing flange. For the small size, we recommend using the 2 insertion tools, see section 13.
3. See fig. 16. Replace the O-ring (9) in the tie rod (7).
4. See fig. 17. In the valve seat (4), install the middle seal (10). Install three valve seat seals (12 and 5). Install the seat seal (14), then the quad ring (15) and piston ring (17).
5. In the upper shaft (2), install the two radial seat seals (11), then install the O-ring (13).

fig. 16

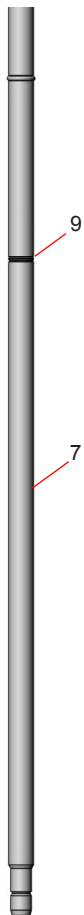
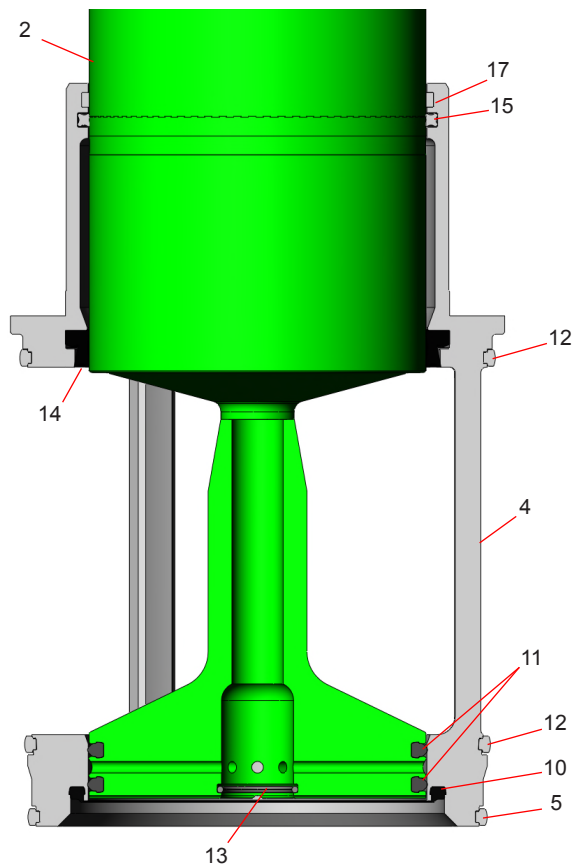

fig. 17



11. Service Instructions

fig. 18

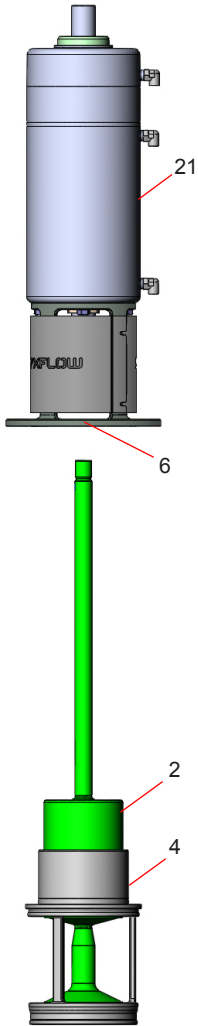
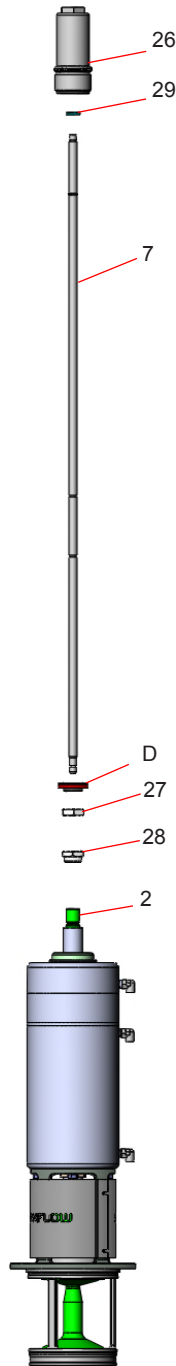

fig. 19



6. See fig. 18. Slide the valve seat (4) over the upper shaft (2).
7. Slide the valve seat and upper shaft assembly into the actuator (21) and yoke assembly (6).
8. See fig. 19. Place the lock washer (28) over the key in the upper shaft.
9. Hold the lock washer (28) with a 30 mm wrench and screw in the safety nut (27) with a 24 mm wrench.
10. Screw the operating cam onto the upper shaft (2).
11. Insert the tie rod (7) into the upper shaft from the top.
12. Slide the thrust ring (29) onto the tie rod (7), then place the stop screw (26) onto the tie rod (7).
13. Screw the stop screw (26) into the actuator (21), using a 32 mm wrench to fully tighten it.

11. Service Instructions

fig. 20

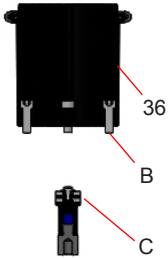

14. Slide the lower shaft (3) onto the tie rod (7).

15. Using a 10 mm wrench, screw the safety nut (19) onto the tie rod (7) to secure the lower shaft (3). Use a 17 mm wrench to prevent the lower shaft (3) from turning.

16. Screw the operating cam (C) onto the top of the tie rod (7).

17. Attach the control top adapter (36) with 4 screws (B).

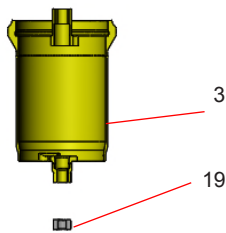
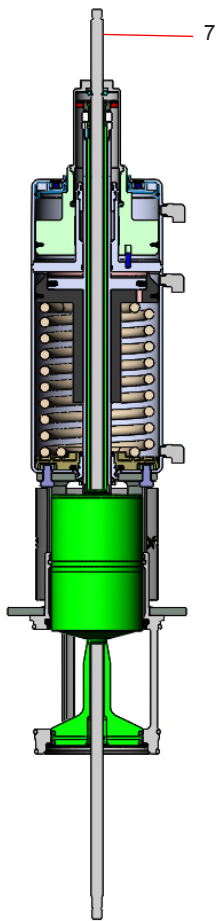

11. Service Instructions

fig. 21

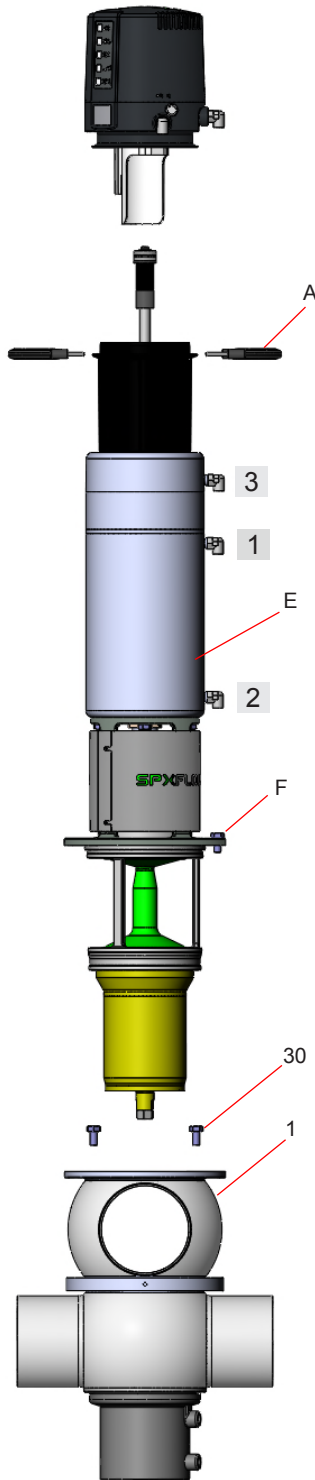

11.4. Installation of the valve insert

1. Carefully place the valve insert (E) in the valve housing (1) until the screw stops.
2. Remove the jacking screw (F) and carefully press the valve insert (E) into the housing (1). (Note: the jacking screw at location F is one of the 4 hex screws (30) used in step 3.)
3. Screw in the hex screws (30) and fasten them in an alternating pattern.
4. Place the control unit on the adapter. Make sure that the control unit is centered on the adapter.
5. Place the clamp ring (A) and fasten it with the screws.
6. Assemble the compressed air lines.
 - D4 PMO Valve:** Air connection 1: to open valve
 - Air connection 2: to lift upper shaft
 - Air connection 3: to lift lower shaft
7. Adjustment of valve position indication / Teach-in:

The continuously measuring valve position measuring system is taught via a reference valve movement.

The respective positions for the closed and open valve position as well as for further valve positions, e.g. seat lifting, are travelled to and the corresponding position of the sensor system is permanently stored in the memory of the electronic module. This process is called Teach-In.

The Teach-In is started by pressing the Teach-In key at the electronic module. The key must be pressed permanently for 3 seconds.

After the start of the Teach-In the LED 9 lights up and the valve travels into the corresponding final positions and back into the basic position. The positions of the corresponding valve positions are stored.

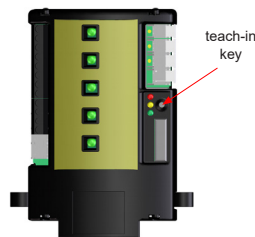

Indication	Status	Action
LED 3-6,9 blink	Delivery status Waiting for teach-in	Start teach-in press teach-in for at least 3 seconds
LED 9 OFF LED 3/4 blink	Teach-in active	Wait Do not control valve via PLC.
LED 9 OFF	Successful teach-in	Valve can be controlled by PLC.
LED 9 ON	Valve service carried out	Start teach-in / press teach-in key for 3 sec.
LED 9 blink	Teach-in not successful, repetition required. Possible reasons for teach-in failure: Compressed air is missing. Supply voltage missing. Switching logic does not fit to valve.	Start teach-in / press teach-in key for 3 sec.

12. Maintenance of Actuator

12.1. Removing the actuator screws

1. Unscrew the two actuator screws (23) with a SW36 socket wrench.
2. Remove the V-seals (24) and O-rings (22).

12.2. Installing the seals and assembling the actuator

1. See fig. 22 and fig. 23. Install the slightly greased O-rings (22) and V-seals (24) in the actuator screws (19). Check the correct installation position of the V-seal (24).

Recommendation for actuator:

Pneumatic grease: Autol TOP 2000
25 ml / tube - Part no. H164725

2. Place the assembly tool (part no. H338580, fig. 24) on the end of the piston rod. Screw the actuator screws (23) with a socket wrench SW36 over the piston rod at both sides of the actuator and fasten them.

fig. 22: D4 PMO Valve actuator

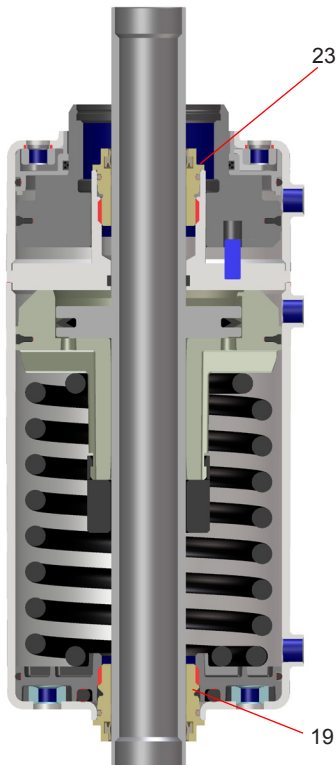

fig. 23: Actuator screw

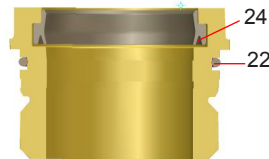
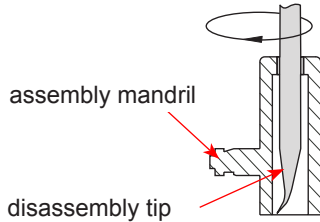

fig. 24: Assembly tool for actuator screw (H338580)



13. Assembly Instructions and Tools for Seals

fig. 25: Assembly/disassembly tool (H171889)



13.1. Lower shaft seal

For the simple assembly of the lower shaft seal (14), the assembly/disassembly tool (part no. H171889) and the assembly stick (part no. H338450) can be used. These tools are especially recommended for valves of small sizes (1.5"-3") as access to the lower shaft seal from the top is difficult as a result of the narrow seat.

See fig. 25. To use the disassembly tip, hold the assembly mandril and turn the handle clockwise to loosen the tip. Continue turning to disengage the tip from the mandril. When finished using the disassembly tip, slide the mandril down over the tip. Hold the mandril in place, then turn the handle counter-clockwise to re-thread the mandril onto the tip and lock it in place.



Caution! To avoid injuries, make sure the disassembly tip is covered by the assembly mandril when it is not being used.

1. Slightly grease the shaft seal (14).
2. See fig. 27. Use the assembly mandril (assembly/disassembly tool H171889) to insert the shaft seal (14) from the top of the valve, making sure to keep the narrow side of the seal facing up. Push the shaft seal down through the intermediate ring of the housing, into the lower flange housing ball.
3. Position the shaft seal (14) using the groove of the assembly mandril (H171889).
4. Press the shaft seal (14) into one spot in the groove of the housing flange and hold the seal in place with the assembly mandril.
5. See fig. 28. While holding the seal in place with the assembly mandril, position the groove of the assembly stick (H338450) on the seal lip. Slightly turn the stick and position the shaft seal (14) in the groove. Work the stick the rest of the way around the seal lip until the shaft seal is completely inserted in the groove.

fig. 26: Assembly stick (H338450)

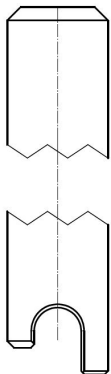

fig. 27

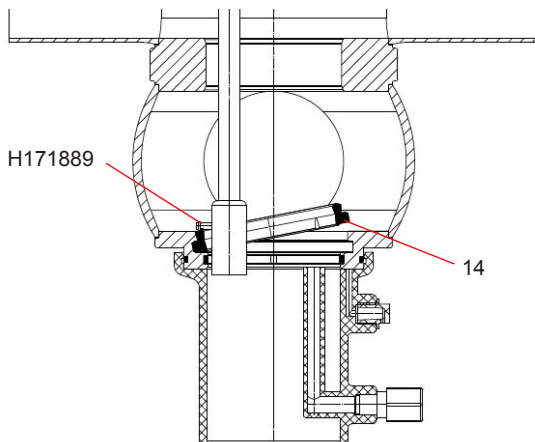
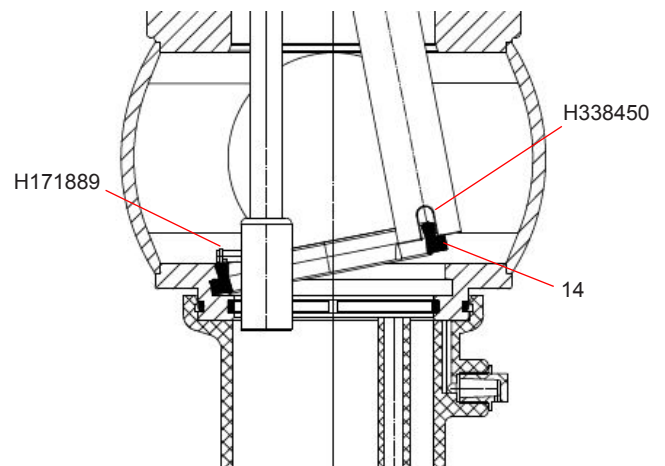
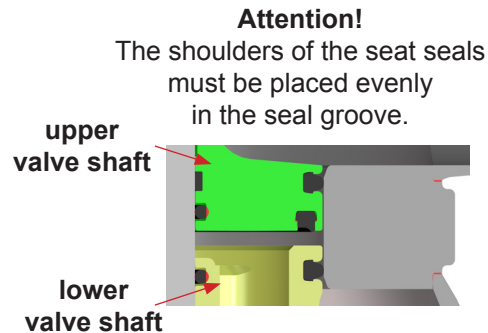
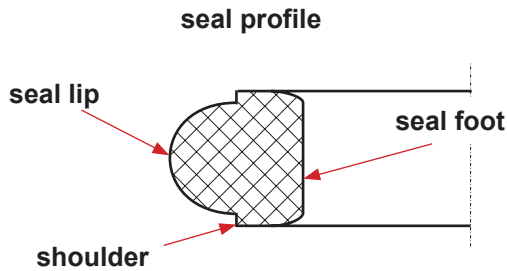

fig. 28



13. Assembly Instructions and Tools for Seals

13.2. Seat seals



1. Provide the seal shoulder with a thin layer of grease.

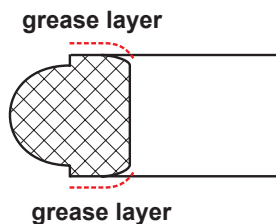

2. Insert the seat seal into the valve shaft, making sure the seal is positioned at an angle, as shown below.

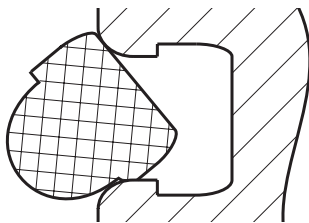

3. Press the seal circumferentially into the groove using the seat assembly tool (part no. 102797+) or a screwdriver with round edges. Place the assembly tool at the upper seal shoulder. To get an even fit of the seal, proceed step by step as follows:

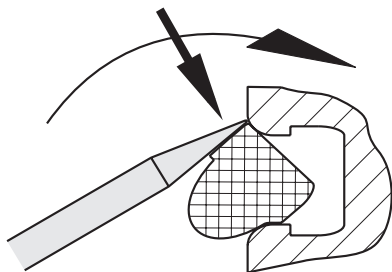

Seat assembly tool,
part no 102797+

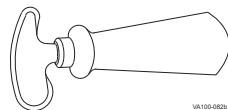

- 3.1. Press a short section of the seal into the groove.

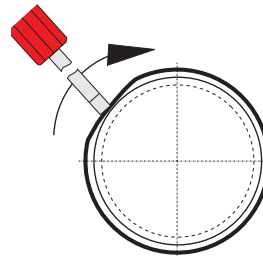

- 3.2. With your finger, hold the section of the seal already pressed in from step 3.1. (This helps prevent loops.) Use the seat assembly tool to press a short section of the seal in the direction of your finger. Continue around the circumference to install the seal into the groove.

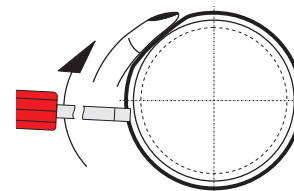

4. Press the seat assembly tool between the seal shoulder and the groove edge (both sides). Proceed around the circumference. Then proceed around the circumference of the lower seal shoulder. This is to vent the seal groove and to lock the seal shoulder.

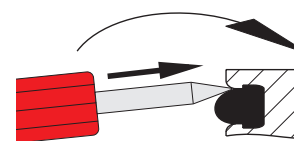

14. Trouble Shooting

Failure	Valve position		Required seal replacement
	closed	open	
Leakage at upper housing flange or yoke	x	x	Upper shaft seal (14)
Leakage from the inside of the lower valve shaft	x		Middle seal (10) or Radial seals (11)
Leakage from the inside of the lower valve shaft		x	Radial seals (11)
Leakage at the outside of the lower valve shaft (remove spray connection for this purpose)	x	x	Lower shaft seal (14)

The numbers refer to the spare parts drawing and parts list starting on page 28.

15. Spare Parts Lists

The item numbers of the spare parts for the different valve sizes are included on the drawing and parts list starting on page 28.

Note!

The last column, "Recomm. spare parts to order with item no. (qty x item)" indicates the quantity and item numbers of the parts which we recommend be ordered together with the part which you intend to replace.

Please indicate the following data to place an order for spare parts:

- number of required parts
- part number

Data is subject to change.

15. Spare Parts Lists

15.1. D4 PMO Drawing

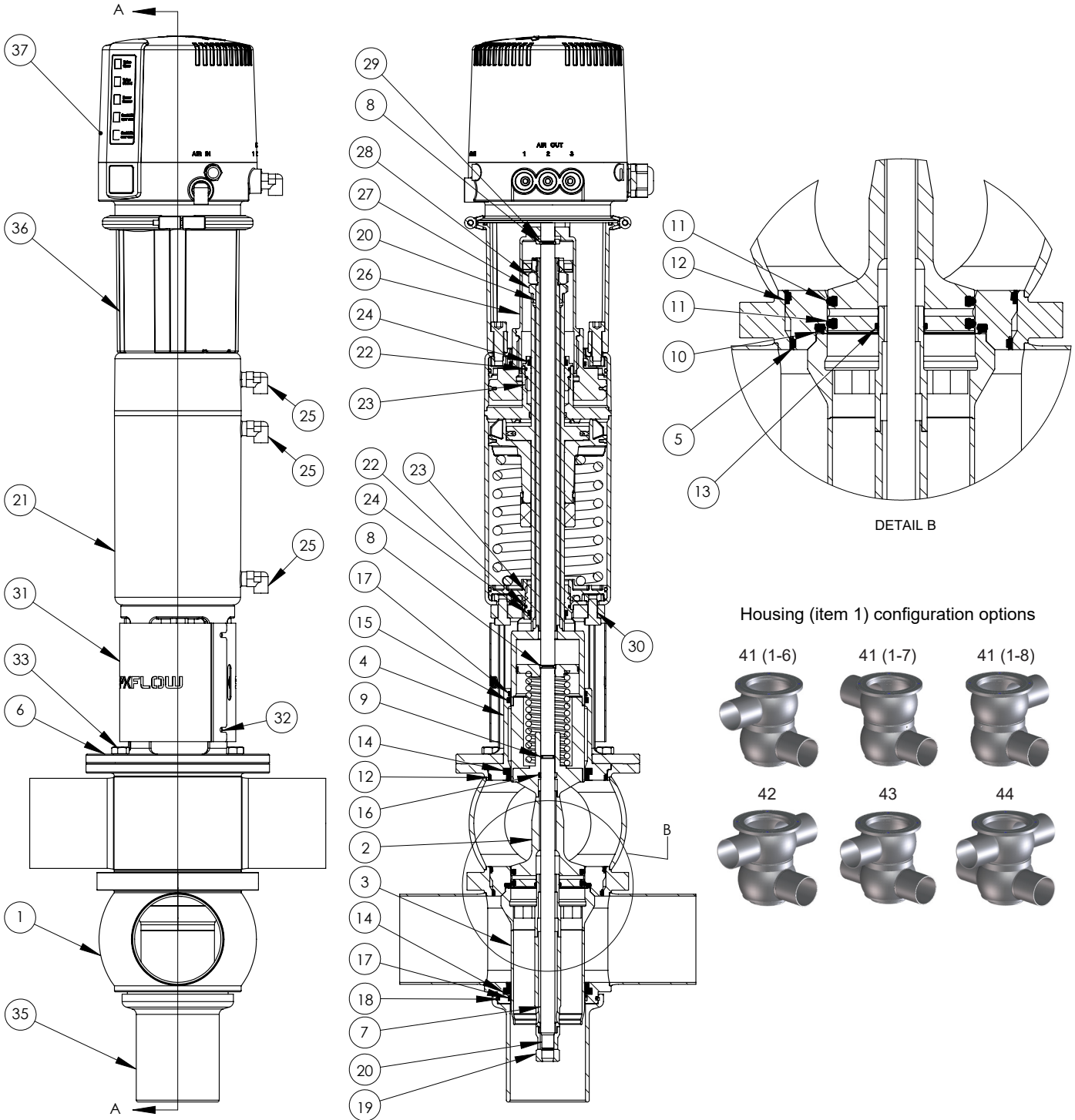

15. Spare Parts Lists

15.2 D4 PMO Parts List

Item	Qty	Description	Material	1.5"	2.0"	2.5"	3.0"	4.0"	Recomm. spare parts to order with item no. (qty x item)
1	1	Housing D41 1-6 PMO	316L	141596+	141603+	141610+	141622+	141629+	1 x 14; 1 x 17
		Housing D41 1-7 PMO	316L	141595+	141602+	141609+	141621+	141628+	
		Housing D41 1-8 PMO	316L	141594+	141601+	141608+	141620+	141627+	
		Housing D42 PMO	316L	141593+	141600+	141607+	141614+	141626+	
		Housing D43 PMO	316L	141590+	141599+	141606+	141613+	141625+	
		Housing D44 PMO	316L	140779+	140782+	140465+	140785+	140788+	
2	1	Upper valve shaft assembly	316L	141679+	141680+	141681+	141682+	141683+	2 x 11; 1 x 13; 1 x 16
3	1	Lower valve shaft	316L	140939+	140789+	140165+	140490+	140791+	
4	1	Valve seat	316L	140992+	140993+	140447+	140994+	141017+	1 x 5; 2 x 12; 1 x 14; 1 x 15; 1 x 17
* 5	1	Valve seat seal	FPM	H77557				H77582	
			EPDM	H77558				H77583	
6	1	Yoke	303	137228+				H335748	
7	1	Tie rod assembly	316L	141684+	141685+	141686+	141687+	141688+	1 x 9
8	2	Retaining ring		H14883					
* 9	1	O-ring	EPDM	E70012					
* 10	1	Middle seal	FPM	141178-73				141233-73	
			EPDM	141178-93				141233-93	
* 11	2	Radial seal	FPM	H171559				H171563	
			EPDM	H168192				H168153	
* 12	2	Valve seat seal	FPM	H77542				H77582	
			EPDM	H77543				H77583	
* 13	1	O-ring	FPM	V70018					
			EPDM	E70018					
* 14	2	Shaft seal	FPM	H337477				H337669	
			EPDM	H337476				H337668	
* 15	1	Quad ring	EPDM	H150898				H148387	
16	1	Guide ring	Iglidur A500	H320447					
* 17	2	Piston ring	Iglidur A500	H334863				H335702	
18	1	O-ring	EPDM	H77039				H77061	
19	1	Safety nut	A2	H118903					
20	2	Square key	A2	H335171					
21	1	Actuator includes 2 each of items 22, 23, and 24		141226+	141227+	141228+	141229+	141016+	
22	2	O-ring	NBR	H337897					
23	2	Actuator screw	Iglidur J350	H334376					
24	2	V-seal	NBR	H334379					
25	3	W-Union G1/8" 1/4"OD		H312732					
26	1	Stop screw	Grivory	141409+					
27	1	Safety nut	304	H147640					
28	1	Lock washer	304	H335172					
29	1	Thrust ring		H123151					
30	4	Hex screw M8 x 20		JT80645				30-633	
31	2	Yoke cover assy (incl. item 32)		141689+				141690+	
32	4	Savetix captive hex screw M4x8 + washer		H336707					
33	4	Hex screw M8 x 16		30-633					
35	1	Spray director		141460+				141691+	1 x 18; 2 x 34
36	1	CU4 D4 adapter		H336441					
37	1	CU4plus D4 AS-i extended Control top 1/4" OD, set for D4SL/D4PMO		H342414					
		CU4plus D4 AS-i extended Control top 1/4" OD M12-4pin, set for D4SL/D4PMO		H342412					
Seal kit, includes items 5, 9, 10, 11, 13, 14, 15, 17, plus lubricant H174858			FPM	141676+				141678+	
			EPDM	141675+				141677+	
Insert, D4 PMO, includes all item numbers except 1, 35, 36, 37.			FPM	141024+	141025+	140484+	141026+	141580+	
			EPDM	141576+	141577+	141578+	141579+	141582+	

* available in seal kits

"Recomm. spare parts to order with item no. (qty x item)" indicates the quantity and item numbers of the parts which we recommend be ordered together with the part which you intend to replace.

Waukesha Cherry-Burrell® Brand D4 PMO Valves

This page intentionally left blank.

D4 PMO

DOUBLE SEAT MIX PROOF VALVES

SPXFLOW

SPX FLOW, Inc.

611 Sugar Creek Road

Delavan, WI 53115

P: (262) 728-1900 or (800) 252-5200

F: (262) 728-4904 or (800) 252-5012

E: wcb@spxflow.com

SPX FLOW, Inc. reserves the right to incorporate our latest design and material changes without notice or obligation.

Design features, materials of construction and dimensional data, as described in this bulletin, are provided for your information only and should not be relied upon unless confirmed in writing. Please contact your local sales representative for product availability in your region. For more information visit www.spxflow.com.

The green "s" and "x" are trademarks of SPX FLOW, Inc.

ISSUED 6/2020 - Original manual

COPYRIGHT ©2020 SPX FLOW, Inc.